

Population Health Colloquium

Preconference I: Executive Briefing

Implementing Population Health for Health Reform

Drew Harris, DPM, MPH
Director, Health Policy Program
Jefferson School of Population Health



A Story of Population Health

Pollution takes heavy toll on Bay Area children with asthma

OAKLAND -- The pediatric inpatient unit was quiet, except for the deep, relentless coughing. It was the sound of asthma -- asthma out of control.

Two of the children who'd spent the night there, oxygen sensors glowing red around their index fingers, were ill, one with a bad cold, the other with pneumonia.



How do we prevent disease and
ensure all people are well,
not just un-sick?

Population Health

(pāpyə'lāSHən)

(helTH)

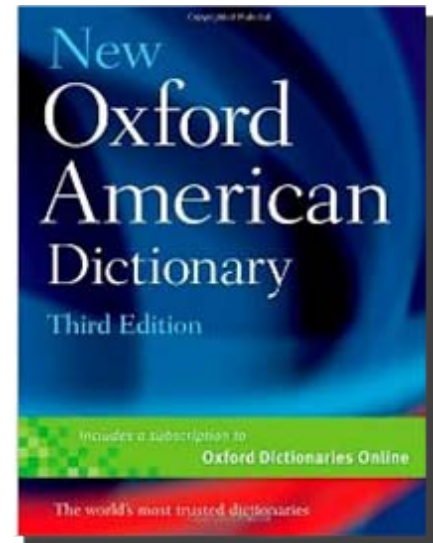

1. *All the inhabitants of a particular town, area, or country;*
2. *A particular section, group, or type of people or animals living in an area or country.*

Kindig & Stoddart

Population Health is . . .

The health outcomes of a group of individuals, including the distribution of such outcomes with the group.

What Is Population Health?

Population health is a relatively new term that has not yet been precisely defined. Is it a concept of health or a field of study of health determinants?

We propose that the definition be "the health outcomes of a group of individuals, including the distribution of such outcomes within the group," and we argue that the field of population health includes health outcomes, patterns of health determinants, and policies and interventions that link these two.

We present a rationale for this definition and note its dif-

David Kindig, MD, PhD, and Greg Stoddart, PhD

ALTHOUGH THE TERM

"population health" has been much more commonly used in Canada than in the United States, a precise definition has not been agreed upon even in Canada, where the concept it denotes has gained some prominence. Probably the most influential contribution to the development of the population health approach is Evans, Barer, and Marmor's *Why Are Some People Healthy and Others Not? The Determinants of*

that in Canada has taken on a "conceptual thinking about the framework."

However, that in the past has been used as a substitute for



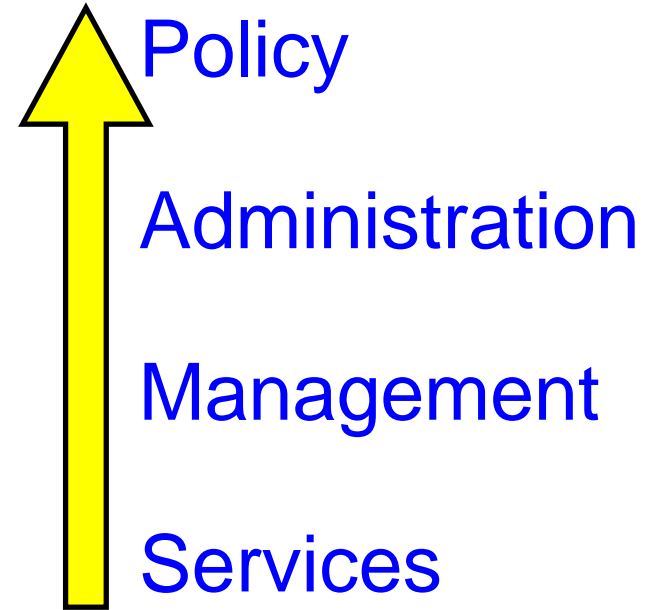
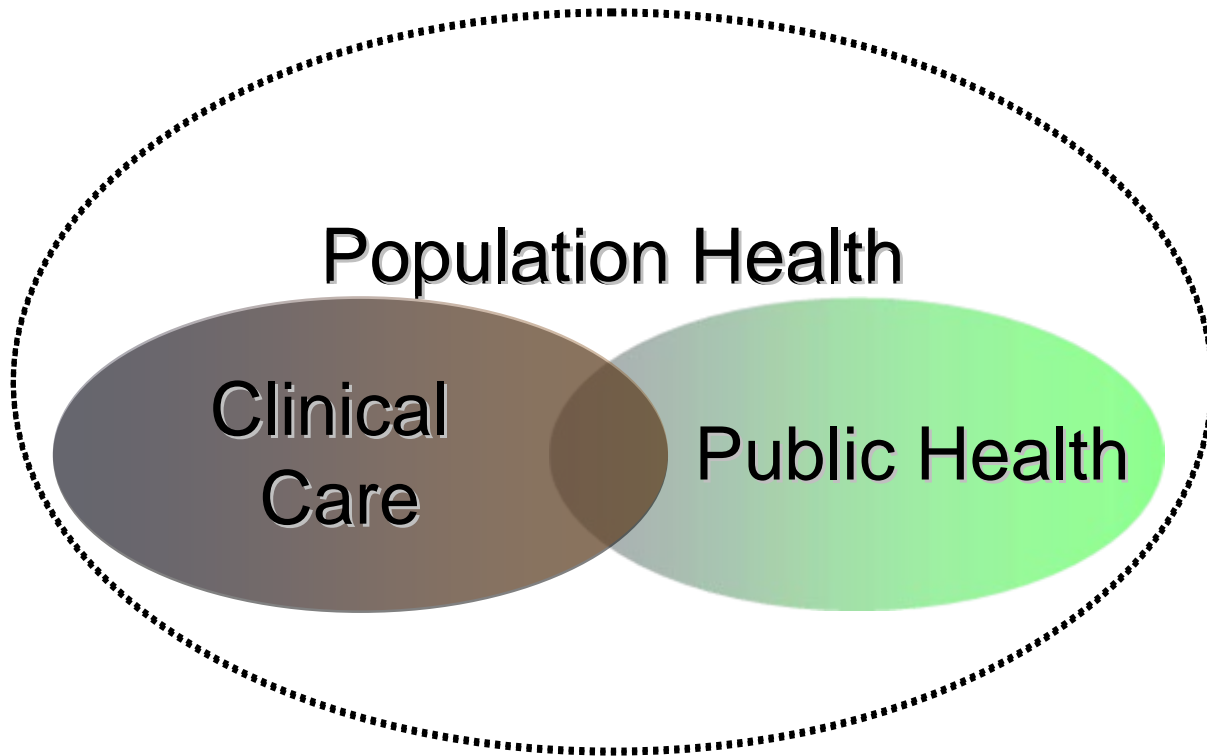

Population Health Perspective

$$1 + 1 > 2$$

>Sum of the parts

Population Health Perspective



B R O A D E R V I E W

Population Health Perspective

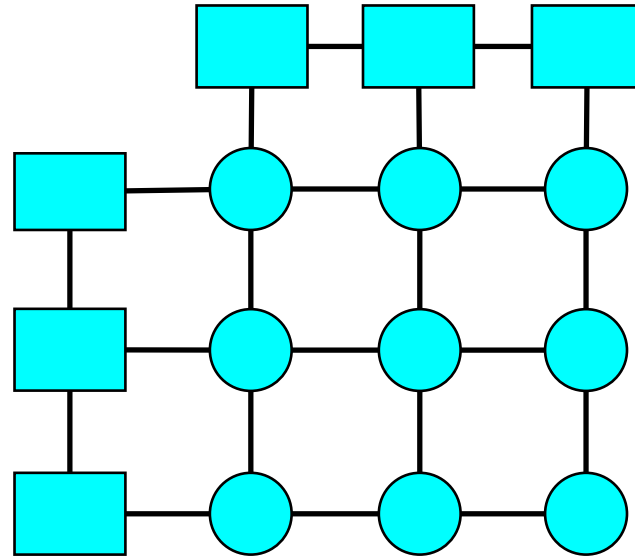

Diffuse Accountability

Population health paradigm

Stakeholder: *Physician*

	Conventional Healthcare System	Population Health
Purpose	Maximize health & wellness of my patients	Optimize health & wellness of a population
Values	Integrity/Compassion/ Personal accountability for practice	Equity/Public Good/Team accountability for health outcomes
Methods	Diagnosis and Treatment	Community Engagement and Prevention
Gaps	Administrative burdens; patient contact.	Community health/wellness failings
Opportunities	Greater autonomy	Cost effectiveness
Assumptions	I am center of authority.	I am center of care team.

Population health paradigm

Stakeholder: *Patient*

Conventional Healthcare System

Population Health

Purpose	Cure my illness.	Keep me healthy and well.
Values	Personal health (episodic)/Convenience/Trust in Physician's Expertise	Personal long-term health/Daily Engagement/Agency and Self-management
Methods	Submit to examination; adhere to treatment plans.	Articulate health & wellness goals/co-design healthy lifestyle.
Gaps	Gaps: Costs, Continuity of Care	Gaps: lack of transparency and evidence-based practice
Opportunities	???	HIT
Assumptions	The system is responsible for "rescuing" me.	I am responsible for my health and wellness as well as demanding a suitable health system.

Determinants

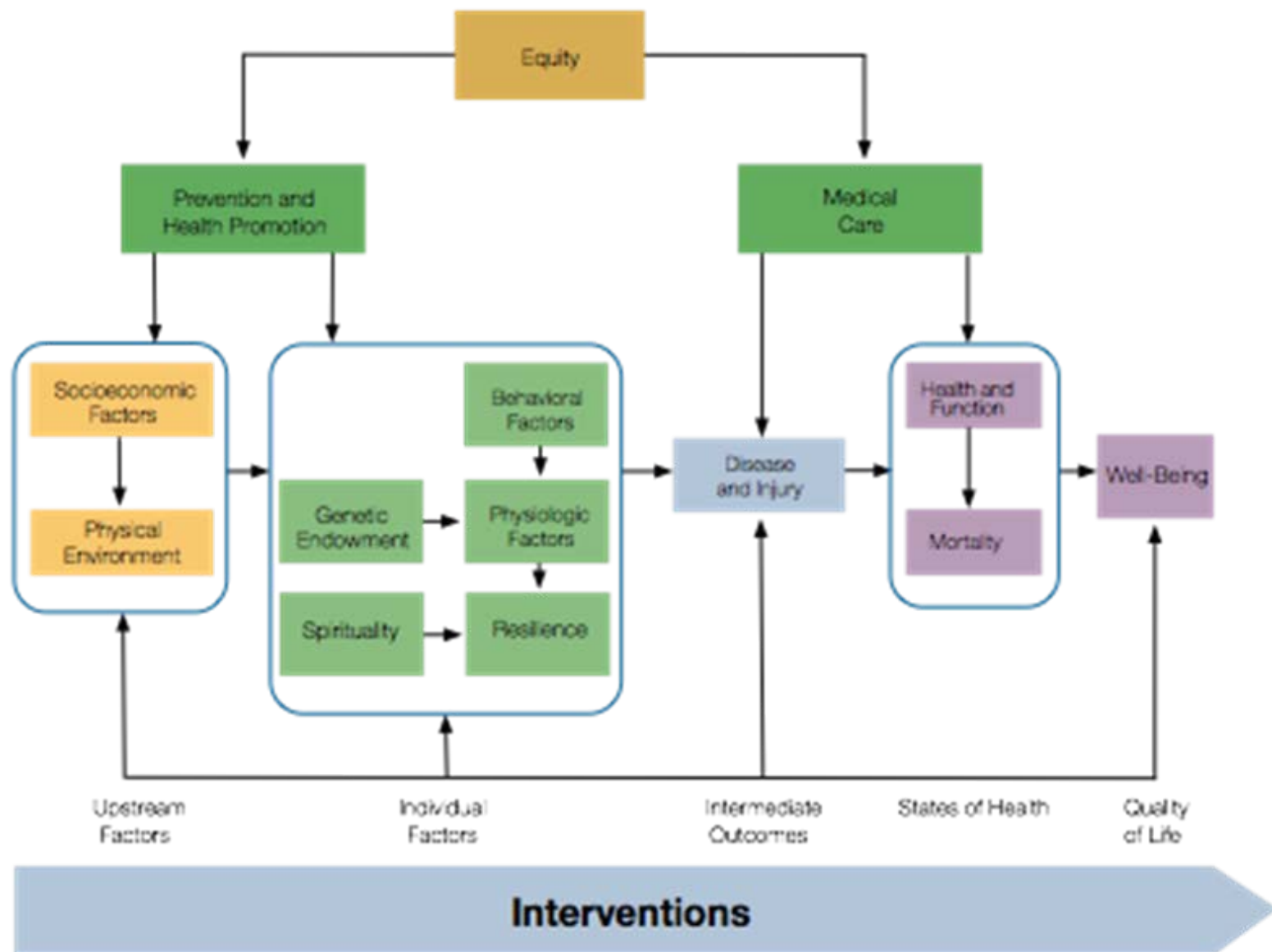

Health Impact Pyramid

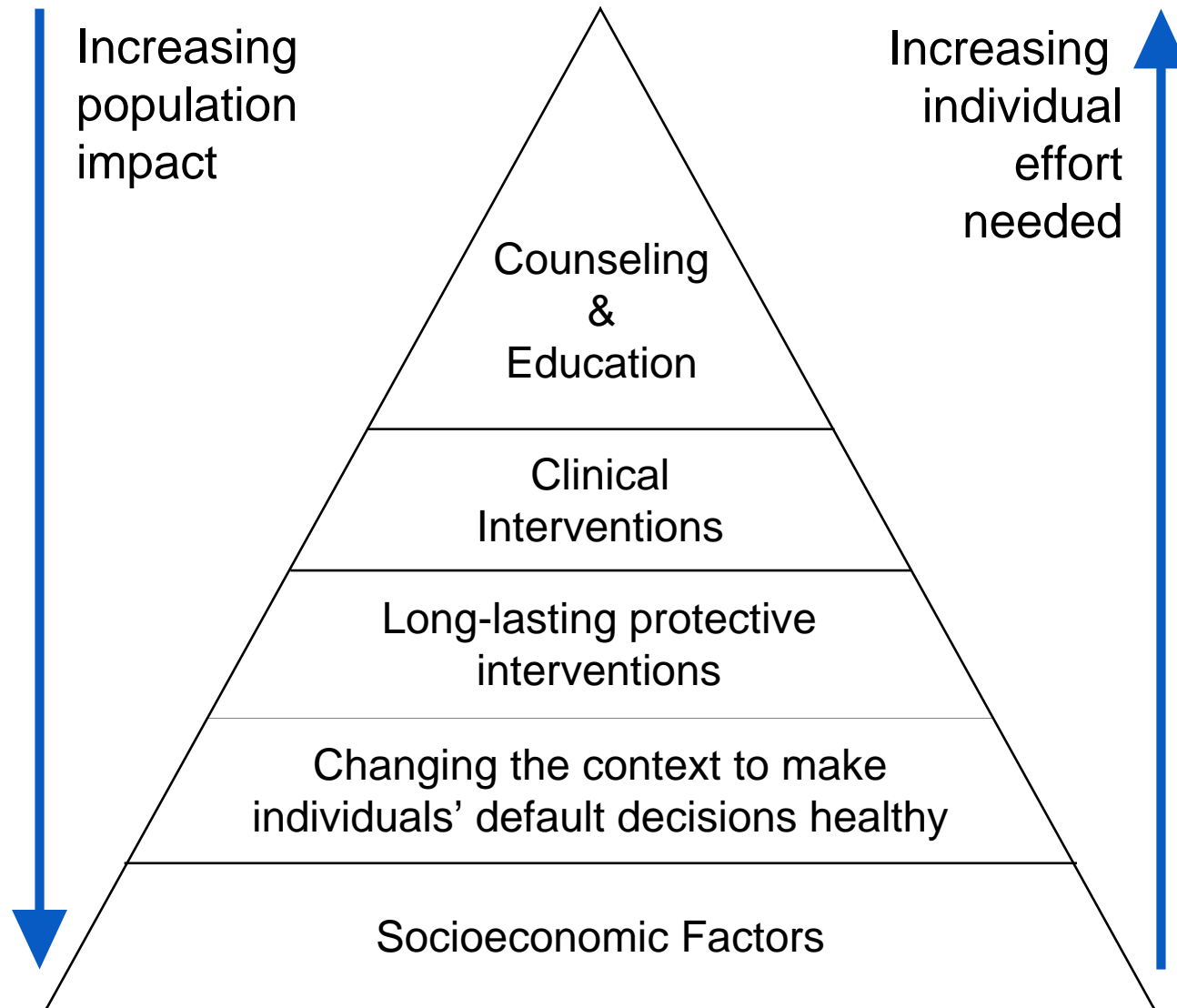

pressure points (legislative)

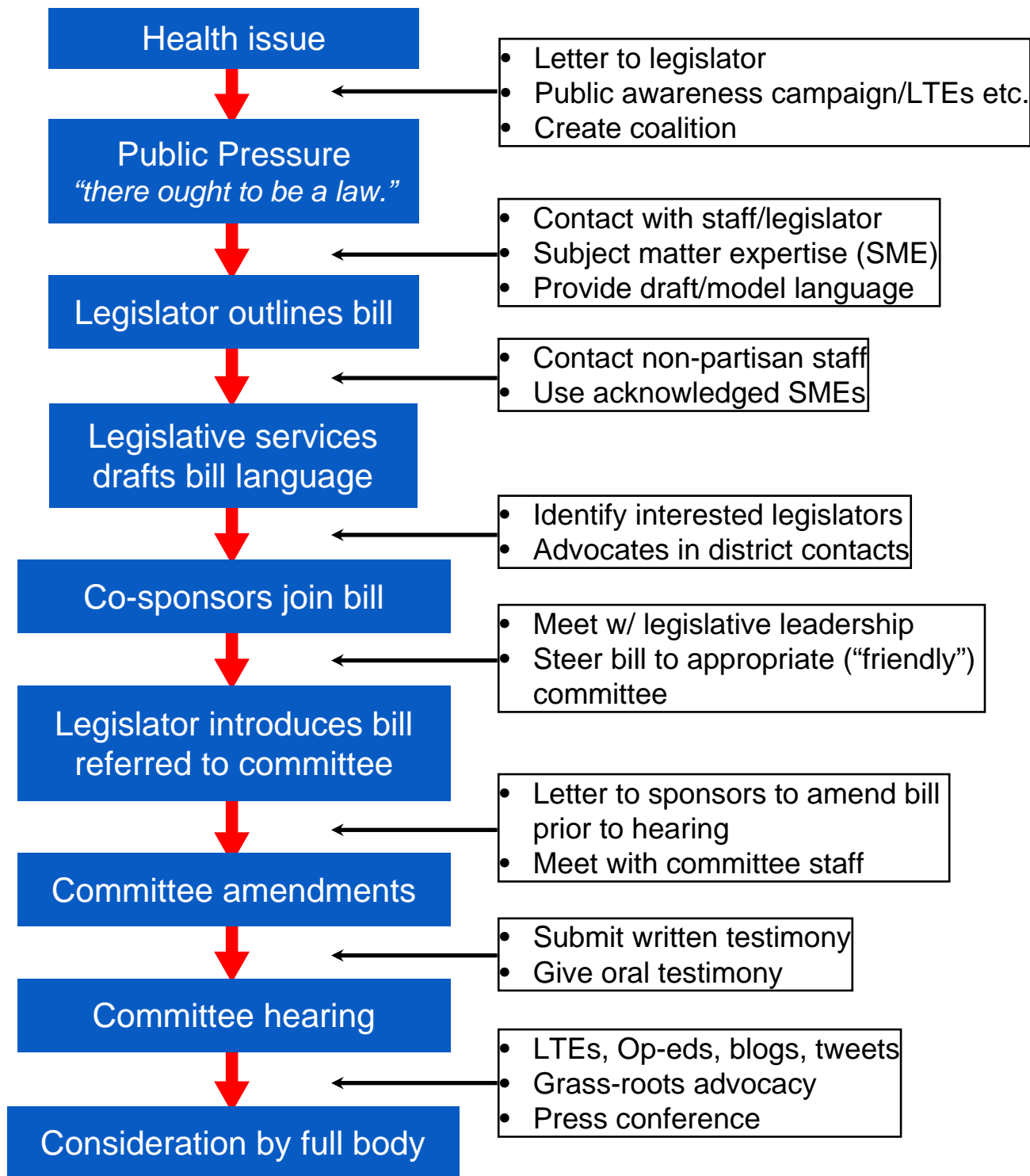

pressure points (administration)

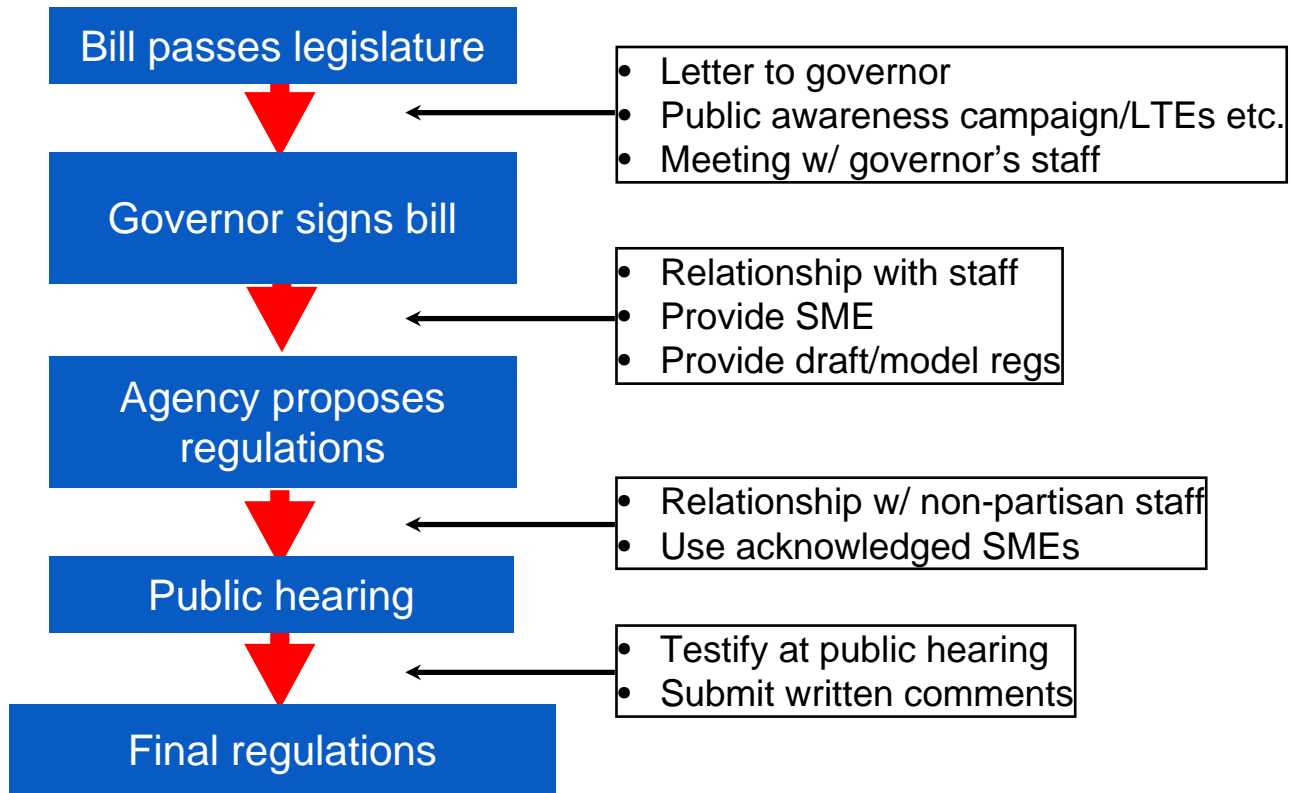

Case study